

Microphones

Two main types

Omnidirectional – gathers sounds from all directions

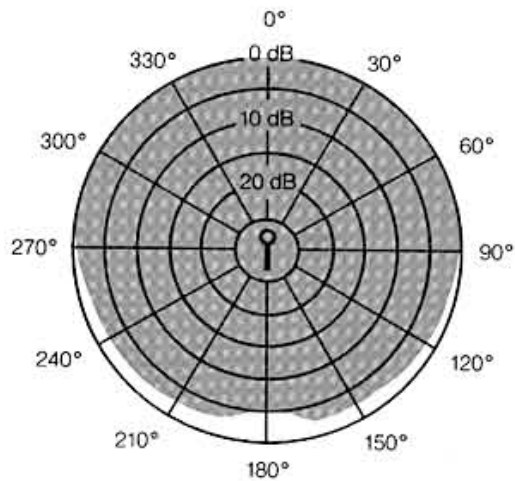

Truest sound
Sturdy
Pickup multiple sources from one mic

Cardioid – heart-shaped pickup pattern

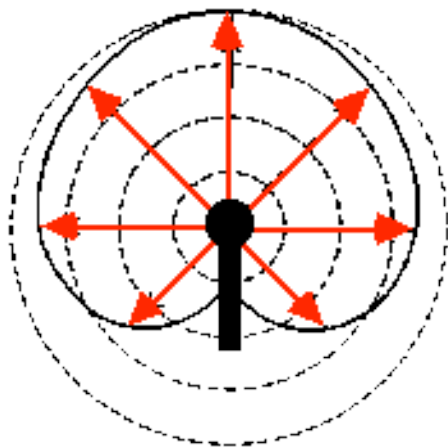

Super-cardioid or hyper-cardioid – very directional pickup

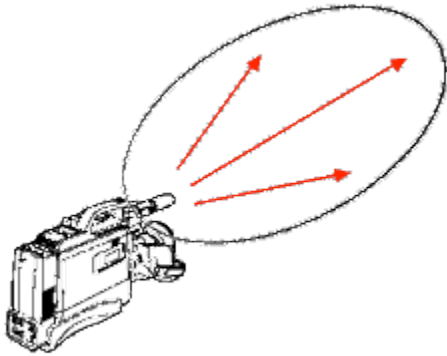

Sensitive to handling noise
Isolates sounds